



گروه فنی مهندسی جوش و برش مقدم

اعتماد از شما کیفیت و تخصص از ما



09153223758



051-37581400



<https://www.moghadamwelding>



<http://instagram.com/moghadam>



<https://t.me/moghadamwelding>



<https://whatsapp.com/channel>



<https://rubika.ir/moghadamwelding>



مشهد خیام شمالی 63 خیابان پردیس 3

برای کسب اطلاعات بیشتر بر روی لینک ها کلیک کنید

- 7 سال سابقه آموزش تعمیرات تخصصی دستگاه های جوش اینورتری تک فاز و 3 فاز
- 7 سال سابقه فروش قطعات الکترونیکی دستگاه جوش تک فاز و 3 فاز
- آموزش تخصصی تحلیل دستگاه های جوش اینورتری مختص ابراز فروشان
- آموزش تخصصی ابراز آلات شارژی

Ceramic PTC Thermistor 15P-101R Datasheet



1. Optimized Protection with Ceramic PTC Thermistor 15P 101R

The Ceramic PTC Thermistor 15P 101R, as detailed in the 15P-101R Datasheet and PTC 15P Datasheet, offers reliable automatic protection from abnormal temperature and current surges. Known as a "self-resetting fuse" or "ten-thousand-time fuse," this thermistor ensures consistent recovery. It is reusable, contactless, noiseless, and spark-free, making it an ideal solution for long-term circuit protection. For more detailed specifications and information on how the Ceramic PTC Thermistor 15P 101R can provide reliable overload protection for welding machines, please visit our [PTC 15P for Welding Machine product page](#).

2. Key Advantages of Ceramic PTC Thermistor 15P 101R

The Ceramic PTC Thermistor 15P 101R, featured in the 15P-101R Datasheet and [PTC 15P](#) Datasheet, offers a range of critical benefits:

1. Automatic Protection and Recovery: Safeguards circuits and restores function after overloads.
2. Contactless, Noiseless, and Spark-Free: Ensures safe and reliable operation.
3. Fast Response Time: Quickly reacts to abnormal current and temperature changes.
4. High Voltage Endurance: Operates across a wide voltage range.
5. Low Steady-State Resistance: Minimizes power loss.
6. Low Rated Current: Optimized for energy efficiency.
7. Compact Size: Easily integrates into space-constrained designs.
8. Long-Term Stability: Maintains consistent performance over time.
9. No Reset Required After Overload: Automatically restores function.
10. Wide Operating Temperature Range:
0 ~ +60°C (V=Vmax)
-25 ~ +125°C (V=0)
11. RoHS Compliant: Meets environmental safety standards.

3. Outlook and Dimensions of 15P 101R (In:mm)

Dimensions (mm)		
1	Dmax	14.5
2	Tmax	7.5
3	F1	7.5
4	L1短	8
5	d	0.8

4. Optimized Electrical Performance Specifications of Ceramic PTC Thermistor 15P 101R

Item	Description	Electrical Parameters
1	Resistance at 25°C (R25):	100Ω ±30%
2	Curie Temperature:	120°C
3	Maximum Operating Voltage (TA=25°C, Vmax):	400V
4	Rated Voltage (TA=25°C, VN):	270V
5	Operating Voltage:	220Vrms
6	Maximum Allowable Current (Imax):	200mA
7	Maximum Continuous Current at 25°C (Imax):	50mA
8	Minimum It Current at 25°C (Imin):	100mA
9	Operating Temperature Range (V=Vmax):	-10~+170°C
10	Storage Temperature Range (V=0):	-10~+60°C

Ceramic PTC Thermistor 15P-101R Datasheet

Materials

*Lead Type: Internal bend *Encapsulation Color: Green
 *Lead Material: CP wire *Encapsulation Material: Silicone rubber

5. Recommended welding conditions for 15P 101R

Wave soldering curve

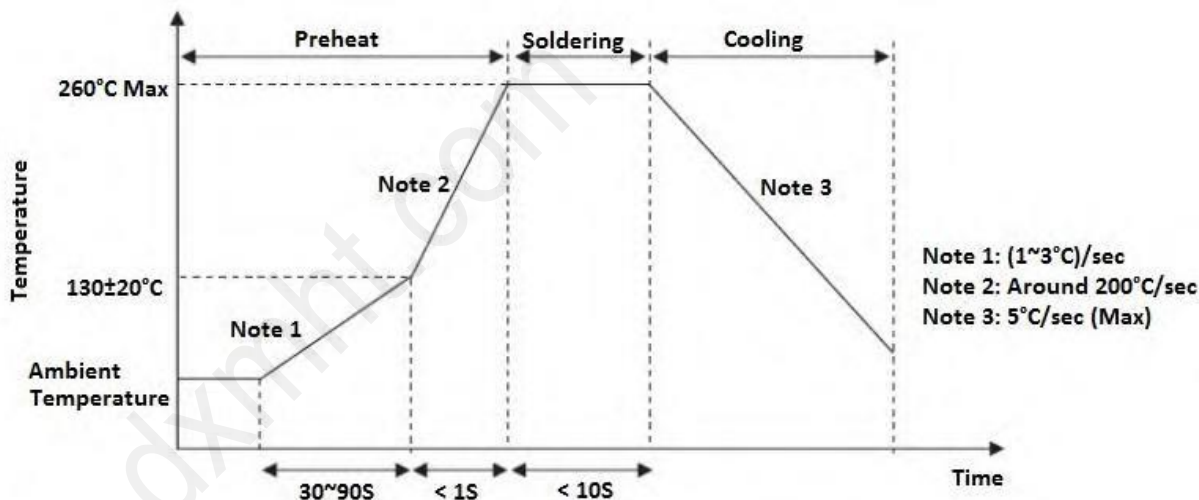

Recommended welding conditions for 15P 101R

Heavy soldering iron welding bar

Item	Items	Condition
1	Soldering iron head temperature	360°C (max.)
2	Weld time	2 sec (max.)
3	Distance between welding position and coating layer	6 mm (min.)

6. How the Ceramic PTC Thermistor 15P 101R Operates

The Ceramic PTC Thermistor maintains low resistance when the current is below its rated value. This allows the circuit to operate normally. When a fault occurs and the current exceeds the limit, the thermistor rapidly heats up, shifting to a high-resistance state. This disconnects the circuit, preventing damage. Once the fault is cleared, the thermistor automatically resets to its low-resistance state, restoring normal circuit function.

For more technical details, refer to the 15P-101R Datasheet and the comprehensive PTC 15P Datasheet.

7. Reliability and Mechanical Performance Tests for Ceramic PTC Thermistor

Mechanical Performance Tests

Test Category	Test Conditions / Methods		Performance Requirements	
	Lead Diameter	Tensile Force		
Lead Tensile Test*	"Body fixed, apply tensile force along the lead direction for 10±1 seconds. Tensile force as per the table below:"	0.6mm	1.0 Kg	No visible damage, Δ R/R25 ≤ 20%
		0.8mm	1.0 Kg	
		1.0mm	2.0 Kg	
Vibration Test*	Fix product on a vibrating device; frequency: 10-55HZ; amplitude: 0.75mm, 3 directions, each for 24 cycles. Total duration: 6 hours		No visible damage, Δ R/R25 ≤ 20%	
Impact Test*	Place the product in the impact device; half-sine wave ΔV=1.0m/s; acceleration: 50m/s ² ; pulse duration: 30ms		No visible damage, Δ R/R25 ≤ 20%	

Ceramic PTC Thermistor 15P-101R Datasheet

Solderability Test*	Dip the lead 4±1mm away from the body into the solder pot at 255±5°C for 3±0.5 seconds.	Tin coverage area ≥ 95%
Solder Heat Resistance Test*	Dip the lead 4±1mm away from the body into a solder pot at 350±10°C for 3~4 seconds.	No visible damage, Δ R/R25 ≤ 20%

Environmental Performance Tests

High Temperature Continuous Load Test	UCT=60°C, VR, It ≦ I ≦ Imax, 1000 hours				No visible damage, Δ R/R25 ≤ 20%
Climatic Sequence Test	Step	Temperature	Humidity	Time	No visible damage, Δ R/R25 ≤ 20%
	1	+40 °C	20%R.H	24hrs	
	2	100 °C	20%R.H	16hrs	
	3	25 °C	20%R.H	2hrs	
	4	+40 °C	90%R.H	24hrs	
	5	0 °C	90%R.H	2hrs	
	6	+40 °C	90%R.H	24hrs	
7	25 °C	90%R.H	(1~2)hrs		
High Temperature Storage Test	60°C, 1000 hours				ΔVB/VB% ≦ ±5%
Steady-State Damp Heat Test	40±2°C, 90~95%RH, 1000±2 hours				No visible damage, Δ R/R25 ≤ 20%
Thermal Shock Test	Cycle according to the table at the right, 5 cycles	Step	Temperature °C	Time	No visible damage, Δ R/R25 ≤ 20%
		1	-40±3°C	30 min.	
		2	Room temperature	15 min.	
		3	85±2°C	30 min.	
		4	Room temperature	15 min.	

8. Packaging and Storage Recommendations for Ceramic PTC Thermistor 15P

Reel packing method description

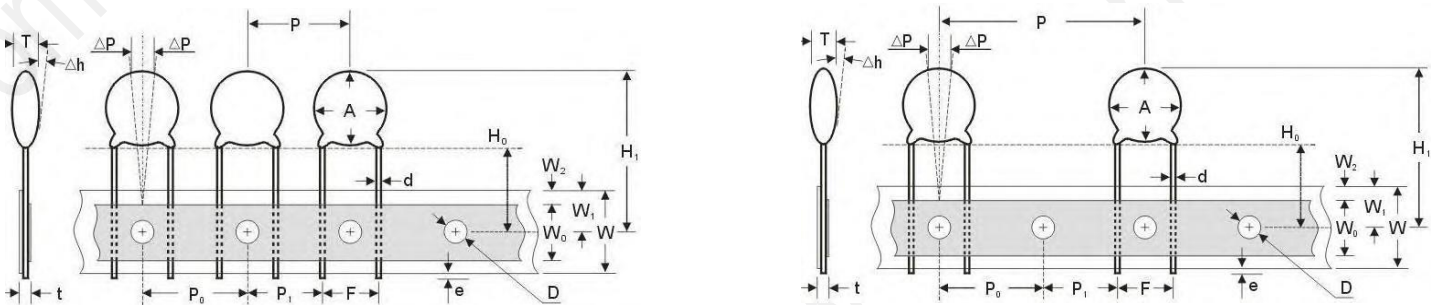

Unit: mm

Item	Parameter	Tab	Standard Size (mm)
1	Product Dimensions	A	15.0×15.0 Max
2	Product Thickness		8.0 Max
3	Lead Diameter	d	0.60±0.05
4	Lead Spacing	P	25.4 Ref
		P	12.7 Ref
5	Tape Hole Spacing (Note:1)	Po	12.7±0.3
6	Allowable offset of component arrangement	ΔP	0±1.3
7	Tape Alignment	P1	7.62±0.7
		P1	8.95±0.7
8	Lead Spacing	F	10.0±1.0
		F	7.50±1.0

Ceramic PTC Thermistor 15P-101R Datasheet

9	Component arrangement allows high and low differences	Δh	0±3.0
10	Tape Width	W	18.0+1.0/-0.
11	Adhesive Tape Width	Wo	13.0 Max
12	Channel location	W1	9.0+0.75/-0.5
13	Tape position	W2	3.0 Ref
14	Height between component and braid center(Note:2)	Ho	16.0±0.5
15	Height of component	H1	40.0 Max
16	Pin terminal protrudes	e	1.0 Max
17	Effective pore diameter	D	4.0±0.3
18	Total braid thickness	t	1.5 Max

REMARKS:1.Cumulative tolerance of continuous hole distance over 20 units over ±1.0 mm.
2.Ho=16.0±0.5 For lead wire type "L".

Reel Packing :

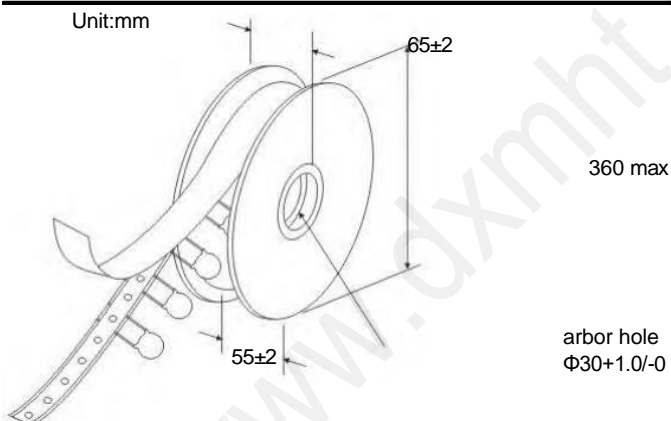

Ammo Packing :

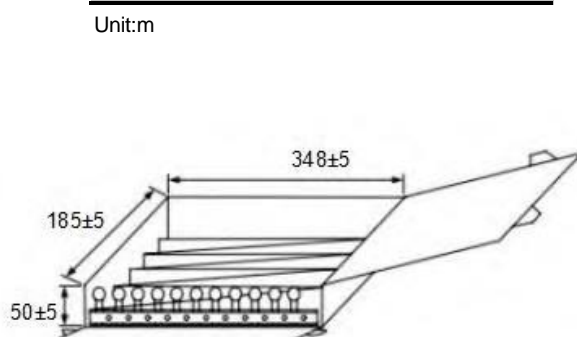

Packing Quaity:

Packing Type	Ceramic PTC Thermistor Diameter	Package Quantity
Reel	≥9.0mm	1000PCS
	<9.0mm	1500PCS
AMMO	≥12mm	500PCS
	<12mm	1250PCS
Bulk	≥12mm	250PCS
	<12mm	500PCS

9. Optimal Storage Conditions for Ceramic PTC Thermistor

To maintain the long-term reliability and performance of the Ceramic PTC Thermistor 15P 101R, follow these recommended storage conditions:

1. Storage Temperature: Keep the thermistor at temperatures between -10°C and +60°C.
2. Relative Humidity: Ensure the humidity does not exceed 75%RH.
3. Avoid Corrosive Environments: Do not store the product in areas with corrosive gases or direct sunlight exposure.

Suggested storage period: 1 year

10. Conclusion

The Ceramic PTC Thermistor 15P 101R offers reliable and efficient overload protection, ensuring long-term stability in various applications. By following the recommended storage conditions—including appropriate temperature, humidity levels, and environment—the thermistor will maintain its performance and reliability for up to 1 year. For detailed technical specifications and further guidance, consult the [15P-101R product page](#). This makes the Ceramic PTC Thermistor a dependable choice for safe and consistent circuit protection.